

Unit : Millimeter[inch]

Spring force

- 14.70g(0.519oz) at initial travel
- 31.00g(1.093oz) at 0.50mm(0.0197) recommended travel
- 35.30g(1.245oz) at 0.63mm(0.0248) full travel

Material & Finish

Plunger	Hardened Beryllium copper	/ Gold Plated
Barrel	Phospher Bronze	/ Gold Plated
Spring	Music Wire	/ Gold Plated

HEAD OFFICE

1547-3, Songjung-Dong, Gangseo-Gu, Busan, Korea
 TEL : +82-51-831-3232 +82-51-831-5897(Overseas Dept)
 FAX: +82-51-831-3233 <http://www.leeno.co.kr>

Electrical Spec.

Current Rating : 1.0A Continuous
 Probe Resistance : Less than 50mohm
 Self Inductance : 0.67nH
 Mutual Inductance : 0.38nH(K=0.5)
 Capacitance : 0.38pF
 Bandwidth : 35.67GHz
 Propagation Delay : 27.04ps
 (Dielectric material : ULTEM1000)

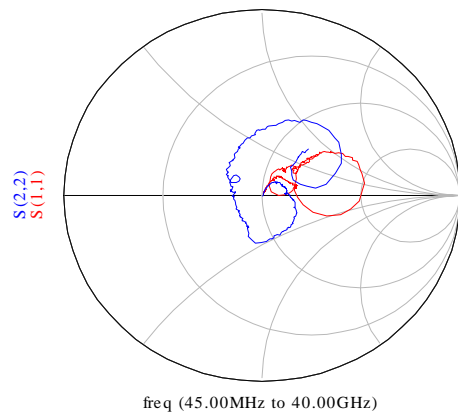
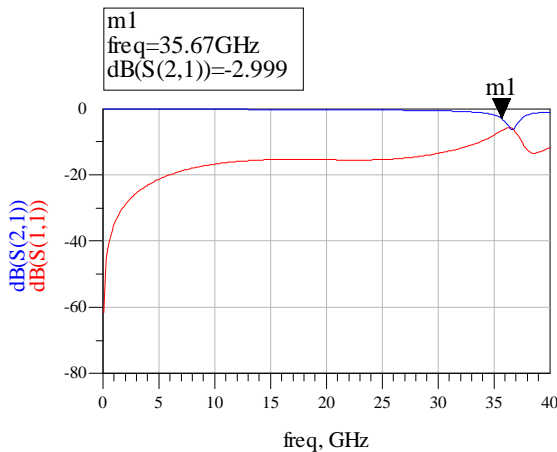

- S-parameter -

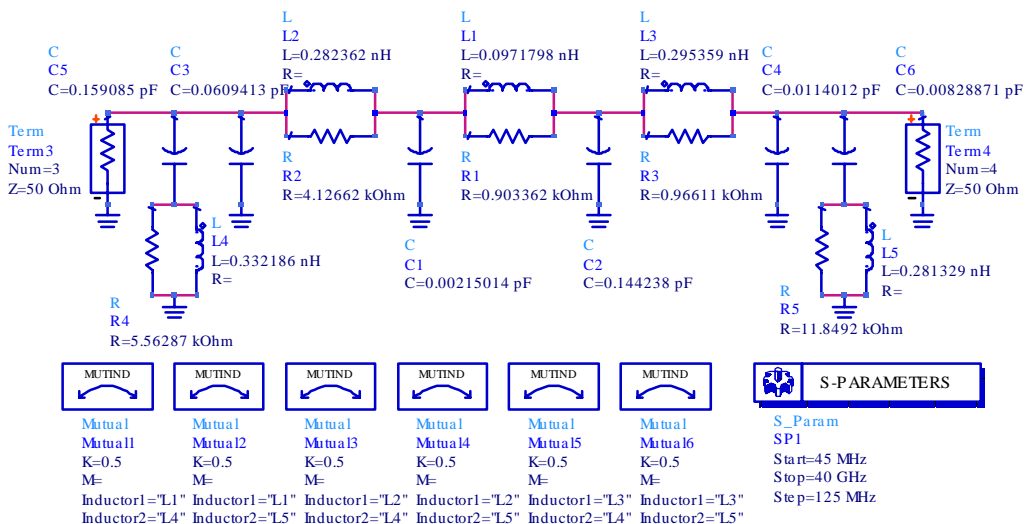

- Equivalent-circuit model -

HEAD OFFICE

1547-3, Songjung-Dong, Gangseo-Gu, Busan, Korea
 TEL : +82-51-831-3232 +82-51-831-5897(Overseas Dept)
 FAX: +82-51-831-3233 <http://www.leeno.co.kr>