

Unit : Millimeter[inch]

### Spring force

4.90g(0.173oz) at initial travel  
 18.50g(0.653oz) at 0.30mm(0.0118) recommended travel  
 22.80g(0.804oz) at 0.40mm(0.0157) full travel

### Material & Finish

Plunger	Hardened Beryllium copper	/ Gold Plated
Barrel	Brass	/ Gold Plated
Spring	Music Wire	/ Gold Plated

### HEAD OFFICE

1547-3, Songjung-Dong, Gangseo-Gu, Busan, Korea  
 TEL : +82-51-831-3232 +82-51-831-5897(Overseas Dept)  
 FAX: +82-51-831-3233 <http://www.leeno.co.kr>

### Electrical Spec.

Current Rating : 0.5A Continuous  
 Probe Resistance : Less than 25mohm  
 Self Inductance : 0.16nH  
 Mutual Inductance : 0.33nH(K=0.5)  
 Capacitance : 0.38pF  
 Bandwidth : 14.30GHz @ -0.998dB  
 Propagation Delay : 11.72ps  
 (Dielectric material : ULTEM1000)

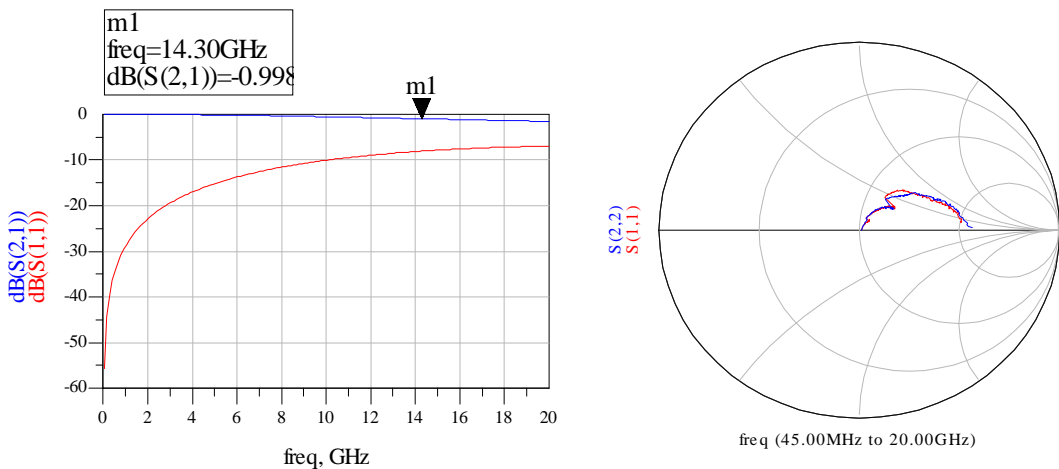

- S-parameter -

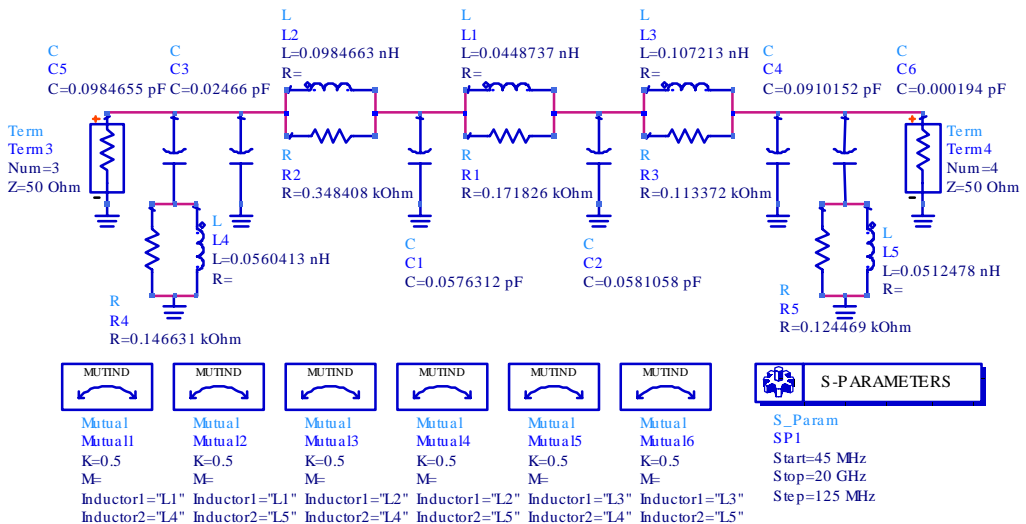

### HEAD OFFICE

1547-3, Songjung-Dong, Gangseo-Gu, Busan, Korea  
 TEL : +82-51-831-3232 +82-51-831-5897(Overseas Dept)  
 FAX: +82-51-831-3233 <http://www.leeno.co.kr>